

UNTHA

The reliable brand!



RS30/40

Shredding solution for economic processing of waste wood

4-shaft cutting system

The tried-and-tested, patented 4-shaft cutting system was developed specifically for tough challenges. The cutting discs are resistant to non-shreddables, were designed for intense, continuous operation and are particularly economical due to their long service life.

Individually adaptable

The cutting system can be customised to the input material and granulate requirements.

Slow-running cutting system

The cutting system is particularly resistant towards metal non-shreddables and stands out for its low dust and low noise production.

Low-wear screen

The screen ensures a defined fraction size.

Compact design

The shredder can be easily integrated into existing systems to defined interfaces.

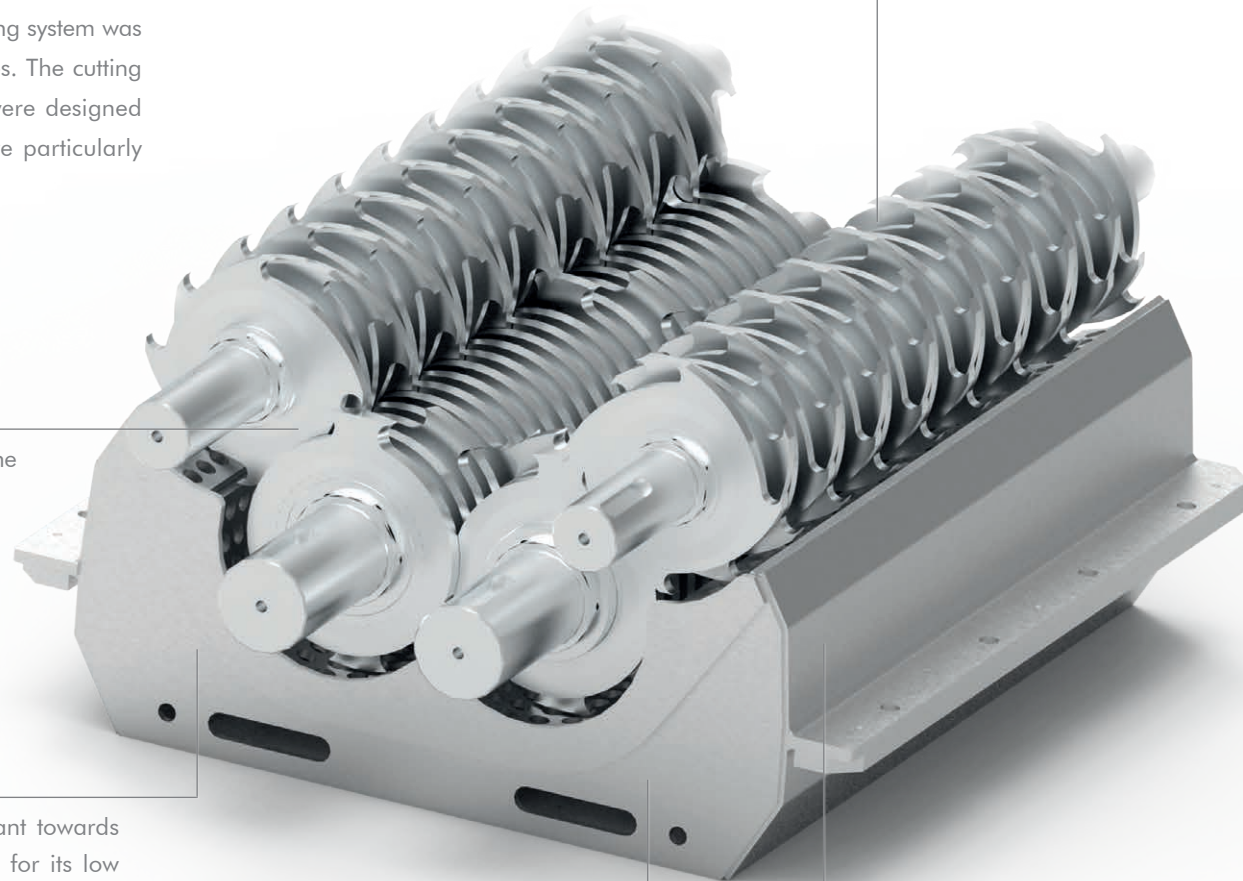

Highly economical

The cutting system has a long service life.

RS30/40

4-shaft shredding system

The highly reliable RS30 and RS40 shredders are used in the woodworking and timber-processing industry. They stand out for their high availability and productivity.

The 4-shaft cutting system may be adapted to the input material and is particularly well suited for processing bark, wet wood, cardboard and residual wood with metal inclusions.

Thanks to their compact design, the 4-shaft shredders are suitable for the decentralised recycling of wood pieces directly next to the production machines. The RS units have a particularly sturdy design that is meant for permanent operation. The low maintenance requirements and high operational performance result in particularly low operating costs.

Areas of application

- » Solid wood (long parts, splinters)
- » Veneers
- » Cardboard/paper (mixed with wood)
- » Bark
- » etc.



Your benefits at a glance



Economical cutting system

The material is pulled in by the cutting system, eliminating the need for a ram device. The four-shaft cutting system ensures a high torque, has a long service life and is highly resistant towards non-shreddables. The low speed keeps noise and dust production to a minimum. Thanks to the wide range of cutting units available, the shredding machine can be customised to meet individual customer requirements, for maximum flexibility.

Long machine lifespan

Easily replaceable wear elements in the cutting chamber extend the service life of the shredder. The maintenance-free labyrinth-seals prevent dust and dirt from entering gears and bearings. The torsion-resistant casting frame construction provides a stable, low-vibration base. The functional design protects the machine components from dirt.



User-friendly display

The shredder's settings can be optimally adjusted to the respective material using the intuitive 5-inch colour display (RS 30 optional). It also helps to quickly analyse and rectify faults.



Defined fraction size

Depending on the requirements, a range of screens ensure the production of pre-defined wood chips. Thanks to chip breakers, the wood chips are particularly homogeneous and precisely adapted to the downstream processing step (briquetting, wood-chip heating system). The large screen area achieves high throughput rates.



Unique warranty

As a proof of our excellent product quality, we are happy to offer you a 3-year warranty*. Many renowned companies already put their trust in our quality standards.

*3 years or 2000 hours, depending on which value is reached first.



Highly user- and maintenance-friendly

Slightly lowering the perforated sieve with screws enables quick replacement and easy service access without counter-holding lock nuts.

Electronic protection systems

The automatic detection and switch-off of impurities and an automatic reversing function protects the drive unit from damage in the event of motor overload. An automatic switch-off switches the machine off when idling and ensures low energy costs.

UNTHA direct drive system

A staggered start-up of the two motors reduces current and power peaks. The simple design of the motor unit (pinion motor - bearing unit - gear-box) reduces susceptibility to faults and minimises maintenance costs.

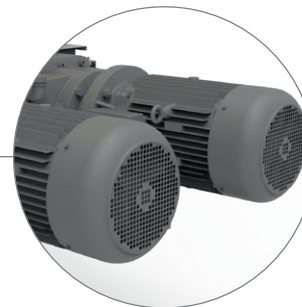

Options

Mechanical extras

- » Tech Pack: mechanical sealing of the bearings on the locating and non-locating bearing, Wear plates on the locating and nonlocating bearing, electrical oil level monitoring
- » Customer-specific chopping discs available upon request
- » Automatic central lubrication
- » Motor covers incl. LED status display

Electrical extras

- » Frequency converter for stepless speed adjustment to reduce current peaks
- » Control system upgrade: light barrier, superordinate control system, BUS system
- » Integration of on-site peripheral devices into the control system
- » Automatic start
- » Control cabinet including display (RS30 optional) and energy recording module

Accessories

- » Customer-specific feed hoppers and machine frame
- » Range of discharge feed systems
- » Various metal separators
- » Extraction hoods

Services

- » UNTHA Carefree Packages Basic, Comfort, Professional ensure that shredders are technically sound and ready for use at all times

RS30/40

4-shaft shredding system

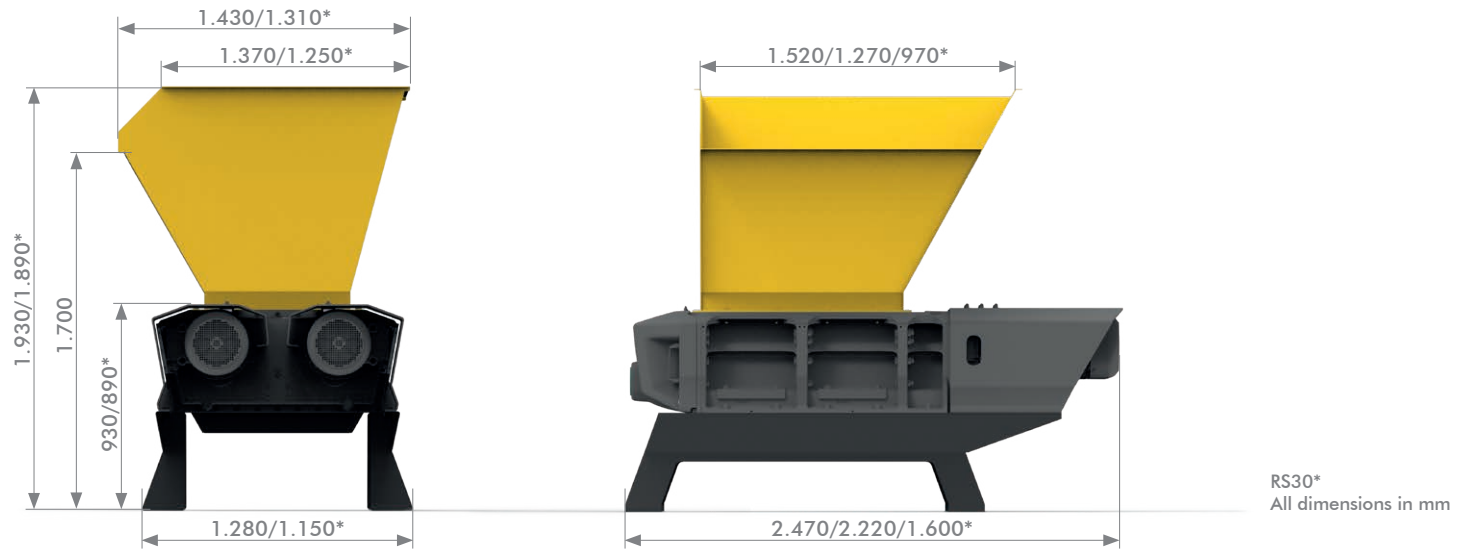

TECHNICAL DATA		RS30*	RS40
Rated capacity of the rotor	kW	11/15/22	30/37/44
Cutter clearance	mm	450 x 600	750/1.000 x 700
Number of shafts		4	4
Speed of the main shaft	rpm	23	24
Speed of the secondary shaft	rpm	34	32
Ø perforated screen	mm	15 - 40	15 - 40
Weight	kg	approx. 1.700	approx. 3.300/3.600
Sound pressure level LP 1m	dB (A)	approx. 80	approx. 80
Throughput* Perforated screen Ø 15 - 25 mm	srm/h	up to 3	up to 7

*) Dependent on type of material and diameter of perforated screen

UNTHA shredding technology GmbH

Kellau 141

5431 Kuchl | Österreich

Tel.: +43 6244 7016 0

info@untha.com

www.untha.com

5 reasons to choose UNTHA



Customised, long-lasting shredding solutions



Premium products developed and manufactured in Austria



All-encompassing expertise, from development to production, under one roof



Reliable customer service with the best technical know-how



More than 10,000 satisfied reference customers worldwide

Authorised UNTHA distribution partner

We deliver what we promise

Since our founding in 1970, we've followed our promise of being "the reliable brand", which applies to every product and service that UNTHA delivers.

We work hard to consistently outperform our competitors, and provide customers with the confidence that – in choosing UNTHA – they have made the best decision for their business.

All revisions reserved. Subject to setting and printing errors.
All illustrations are representative and may deviate from the actual product.
© 10/25 UNTHA shredding technology